



04 – 13 September 2025

The Organizing Authority is the Sailing Club Mornar (SCM) as sanctioned by the International Star Class Yacht Racing Association (“ISCYRA”)

Uvala Baluni 1, 21000 Split, CROATIA

[worlds.starchampionships.org](https://worlds.starchampionships.org)

INITIAL VERSION: August 26, 2025.

## SAILING INSTRUCTIONS (SIs)

The notation **[NP]** in a rule in the SIs means it shall not be grounds for protest by a boat. This changes RRS 60.1.

The notation **[SP]** in a rule in the SIs means it is a rule for which a standard penalty may be applied by the Race Committee (RC) or Technical Committee (RC) without a hearing.

### 1. RULES

- 1.1. NoR 1 contains a list of rules for this event. Competitors are reminded to take note of these.
- 1.2. **[NP]** The RRS changes for using Vakaros RaceSense will be identified in Addendum 1.
- 1.3. STCR 34.6.3 provides that boats not finishing within the stated time after the first boat sails the course and finishes within the time limit will be scored “TLE” as defined therein. This changes RRS 35, RRS A5, and RRS A10.

### 2. CHANGES IN THE SAILING INSTRUCTIONS

- 2.1. Any change to the SIs will be approved by the Principal Race Officer (PRO) and will be posted by 1000 on the day it will take effect unless there is a postponement ashore. In the case of a postponement ashore, a change may be posted up to 30 minutes before the removal of flag ‘AP’. Any change in the schedule of races will be posted by 2100 on the day before it will take effect.
- 2.2. Any change to the SIs will be posted on the Official Notice Board (ONB) available at the following link: <https://worlds.starchampionships.org/race>

### **3. COMMUNICATION WITH COMPETITORS**

- 3.1. Notices to competitors will be posted on the ONB.
- 3.2. Courtesy copies of notices and documents from the ONB may be posted on a physical notice board located on the south wall next to the boat hangar at Sailing Club Mornar.
- 3.3. A WhatsApp group has been set to manage the day-by-day updates during the event and to share reminders. The WhatsApp Group chat is a courtesy of the OA and has no official status. Please be informed that anyone who joins the WhatsApp group can see any other member's WP contact number. To join the WA group, use the link posted at ONB.
- 3.4. Failure to post notices on the Courtesy board or WhatsApp groups will not be grounds for redress.
- 3.5. On the water, the Race Committee intends to monitor and communicate with competitors and Support Persons via VHF radio on channel 69.
- 3.6. Boats may be hailed by Race Officials by either Bow or Sail number.
- 3.7. **[NP]** Failure of any information to be given or received shall not be grounds for redress. Information gathered on any other VHF channel or RC communication channel shall not be grounds for redress, except when a request for redress under this instruction is initiated by the RC or the Jury. This changes RRS 61.1(a).

### **4. [DP] CODE OF CONDUCT**

- 4.1. Competitors, Support Persons and Support Vessels are requested to monitor VHF 69 and shall comply with reasonable requests from Race Officials. Note RRS 37.

### **5. TEAM WEIGHT**

- 5.1. All Teams must demonstrate compliance with STCR 31.1.3 between 1000 on 05 September and before the end of measurement, at 1700 on 07 September.
- 5.2. All Teams must redemonstrate compliance with STCR 31.1.3 on Wednesday, 10 September. Weighing will begin at the Protest Time Limit (PTL) and be available for 3 hours.
- 5.3. All Teams not complying with SI 5.2, shall be scored DSQ for all races sailed on September 10. This changes the last sentence of RRS 60.5(c) and SI 15.3.
- 5.4. Teams unable to comply with SI 5.2, shall have the opportunity to demonstrate compliance with STCR 31.1.3 on Thursday, 11 September from 0700 - 0900. The location will be in the boat hangar.

### **6. SIGNALS MADE ASHORE**

- 6.1. Signals made ashore will be displayed from the flagpole located on the top of the central pier in the club's harbor.
- 6.2. When flag AP is displayed ashore, "1 minute" is replaced with "not less than 60 minutes" in Race Signals AP.

## 7. SCHEDULE

- 7.1. As per STCR 27.2, six (6) races are scheduled.
- 7.2. The RC may change the schedule. Two races per day may be sailed, per the Format being sailed per STCR 34.3.9. The RC reserves the right to get one race ahead of schedule should expected sailing conditions warrant.
- 7.3. To alert boats that a race will begin soon, the orange starting line flags will be displayed with one sound at least five minutes before a warning signal is made.

Thursday, 04 September 2025	10:00 – 18:00	Registration and Inspection of boats
Friday, 05. September 2025	10:00 – 18:00	Registration, Inspection of boats, Team Weigh-In
Saturday, 06. September 2025	10:00 – 18:00	Registration, Inspection of boats, Team Weigh-In
Sunday, 07. September 2025	10:00 – 17:00 10:00 12:55 18:00 TBD	Last Registration, Boat Inspection, Team Weigh-In RaceSense Check-In Deadline (Vakaros Atlas 2) Practice Race All boats afloat <b>Opening Ceremony</b> (dress code: Blazer)
Monday, 08. September 2025 Race Day 1	10:00 12:55 After Racing	Skippers Meeting Warning Signal Social hour with snacks and beer
Tuesday, 09. September 2025 Race Day 2	12:55 After Racing	Warning Signal Social hour with snacks and beer
Wednesday, 10. September 2025 Race Day 3	12:55 PLT + 3 hours TBD	Warning Signal Midweek Team Weigh-in per SI 5.2. <b>Midweek Dinner</b> (dress code: Blazer)
Thursday, 11. September 2025 Race Day 4	07:00 – 09:00 12:55 After Racing	Weigh-in per SI 5.4. Warning Signal Social hour with snacks and beer
Friday, 12. September 2025 Race Day 5	12:55 After Racing	Warning Signal Social hour with snacks and beer
Saturday, 13. September 2025 Race Day 6	12:55 TBD	Warning Signal <b>Prize Giving Ceremony</b> (dress code: Blazer)

## **8. CLASS FLAG**

- 8.1. The Class Flag will be a white flag with a red star.

## **9. RACING AREAS**

- 9.1. The racing areas will be in the Split channel.
- 9.2. There will be two racing areas, Alpha and Bravo.
- 9.3. If RC intends to use racing area Bravo, it will display a red flag ashore at least 2 hours before the scheduled warning signal.

## **10. [NP] COURSES**

- 10.1. Per STCR 34.3, Course 0, Course 1, Course 3, Course 4, Course 6, or Course 7 (consistent with the Format being sailed, STCR 34.3.9) will be used. See ADDENDUM 6.
- 10.2. No later than the warning signal, the RC signal vessel will display the course and the approximate compass bearing and distance of the first leg.

## **11. MARKS**

- 11.1. Mark 1 (Windward), Mark 2 (Reach), Mark 1A (Offset) and Mark 3S/3P (Leeward Gate) will be orange robotic inflatable cones.
- 11.2. The starting marks will be the RC signal vessel at the starboard end, and the RC pin end vessel at the port end.
- 11.3. The finishing marks will be the RC signal vessel at the starboard end, and the RC pin end vessel or the course side of an orange robotic inflatable cone at the port end.
- 11.4. Change of course marks, 1, 1a, and 2 will be yellow robotic inflatable cones.

## **12. THE START**

- 12.1. RRS 26 is changed per Addendum 1. The countdown to the starting signal on the Atlas 2 / Atlas Edge from RaceSense will be the official time.
- 12.2. The starting line will be between a staff displaying an orange flag on each of the starting marks.
- 12.3. A boat not starting within ten (10) minutes of the starting signal will be scored "Did Not Start" (DNS) without a hearing.
- 12.4. An RC vessel displaying code flag G may pass to windward of the fleet in the event of an abandonment, postponement, or general recall, which means, "The RC has signaled an abandonment, postponement, or general recall. Boats shall return to the starting area immediately."
- 12.5. Boats identified OCS, UFD or BFD shall leave the racecourse immediately. Boats may be informed either via Vakaros RaceSense, or an RC vessel positioned near Mark 1 may attempt to notify boats by displaying the appropriate starting penalty flag and their bow or sail numbers.

**13. CHANGING THE NEXT LEG OF THE COURSE**

- 13.1. To change the next leg of the course, the RC will lay a new windward or reach mark or move the gate or finish line and, as soon as practicable, remove the original mark (s).
- 13.2. When the position of the windward mark is changed, the offset mark will be re-laid.
- 13.3. When, in a subsequent change, a new mark is replaced, it will be replaced by the original mark.
- 13.4. **[NP]** In addition to signaling the change from an RC vessel, the RC will attempt to announce the change on VHF Channel 69 as boats approach the RC vessel signaling the change.
- 13.5. If the RC changes the position of the gate, the original gate marks will be relocated. If only one leeward mark is set, this mark shall be left to port. This mark is not considered a gate, and RRS 18.4 will apply.

**14. THE FINISH**

- 14.1. The finish line will be between a staff displaying an orange flag on each of the finishing marks. This changes Race Signals.

**15. PENALTY SYSTEM**

- 15.1. Appendix T will apply.
- 15.2. Appendix T1 (b) is changed to read: A Post-Race Penalty is a Scoring Penalty equal to 30% of the score for DNF, or 50 % of the difference between the boat’s finishing position in the race and the score for DNF, whichever is less. The Scoring Penalty is calculated as stated in rule 44.3(c). However, rule 44.1(b) applies.
- 15.3. After a hearing, penalties for violations of rules other than those of RRS Part 2 will be at the discretion of the Jury.

**16. TIME LIMITS**

- 16.1. The time limits will be as specified in STCR 34.3.9 and 34.6.3 for the Format being sailed in the event.

<b>Time limit for the first beat</b>	<b>Time limit to complete the course</b>	<b>Time limit from the first boat</b>
45 minutes	3.5 hours	60 minutes

**17. HEARING REQUESTS**

- 17.1. Hearing requests shall be delivered online. Online forms are available through the ONB Jury at this link: <https://worlds.starchampionships.org/race>. QR codes found on the courtesy noticeboard will also link to the appropriate online forms. This changes RRS 60.3(a) and 61.2(a)
- 17.2. Only in case of technical issues, paper forms will be available at the Race Office (RO).

- 17.3. The protest time limit shall be one (1) hour after the docking time of the RC finishing vessel. When the signal “no more racing today” is displayed ashore, the protest time limit is 30 minutes after the signal is displayed. This changes RRS 60.3. (b) and 61.2 (b). The protest time limit will be posted on the ONB-Jury.
- 17.4. Notices for hearings will be posted on the ONB-Jury no later than 30 minutes after the protest time limit to inform competitors of hearings in which they are parties. Hearings will be held in the Jury room located on the first floor inside the boat’s hangar. Parties and their witnesses should report there at the scheduled time.
- 17.5. Within the protest time limit, the RC shall post on the ONB-Jury, the bow or sail numbers of all boats that are disqualified or penalized under RRS A5.1.

## **18. SCORING**

- 18.1. The scoring system is the Low Point System in RRS Appendix A.
- 18.2. TLE is defined as the theoretical average score of all boats not finished and still sailing the course at the close of the time limit from the first boat.
- 18.3. As per STCR 27.1, five (5) races are required to be completed to constitute a series.
- 18.4. A boat’s series score will be the total of her race scores with her worst score discarded when five (5) or more races are completed.
- 18.5. There will be a Junior division, Master’s division, a Grand Master’s division. Entrants in these divisions will also be competing for the overall Championship. (see also SI 26).
- 18.6. To request correction of an alleged error in posted race or series results, a boat may complete a scoring inquiry form available on the ONB-Jury at this link:  
<https://worlds.starchampionships.org/race>.

## **19. [NP] [DP] LIABILITY, SAFETY, AND CHECK-IN**

- 19.1. The safety of a boat and her entire management, including insurance, shall be the sole and inescapable responsibility of the owner and/or entrant.
- 19.2. Competitors leaving the racecourse before the end of a race shall inform the RC as soon as possible or the race office upon returning to shore.
- 19.3. Competitors not leaving the dock on a race day shall inform the race office.
- 19.4. **[SP]** Any boat choosing to sail out shall, before the warning of the first race of each day, check in with, and be recognized by, the RC signal vessel displaying Flag “L”. Failure to do so will result in a scoring penalty of 5 points added to the boat’s finish score for the first race that day.

## **20. REPLACEMENT OF CREW OR EQUIPMENT**

- 20.1. Any request for a change of crew shall be submitted to the RC in writing before 0930 on the day of the race for which the change is to be made. If permission is granted, it will be done in writing and posted on the ONB.
- 20.2. A change of helmsman will not be permitted.

20.3. Substitution of damaged or lost equipment will not be allowed unless authorized by the Technical Committee (TC). Requests for substitution shall be made to the TC at the first reasonable opportunity.

## **21. [NP] [DP] EVENT ADVERTISING**

21.1. Boats shall display event advertising supplied by the OA. If this rule is broken, World Sailing Regulation 20.9.2 applies.

## **22. OFFICIAL VESSEL**

22.1. [NP] Official vessels will be marked as follows:

- Race Committee Vessel: White Flag with "RC" letters
- Jury vessels: White flag with "JURY"
- Press vessels: White flag with "PRESS"
- TC vessel: White flag with black "M"
- Emergency Vessel: White flag with red cross
- Patrol Vessels: Motorboats with the word "POLICIJA" on hull

## **23. [DP] SUPPORT PERSON / VESSELS**

23.1. Coach vessels, support vessels, and private spectator vessels are expected to monitor VHF channel 69 and to help a boat in danger when requested by the boat, or at the request of the RC or Jury. See RRS 37.

23.2. Coach vessels, support vessels, and private spectator vessels shall stay 100 meters outside areas where boats are racing from the time of the warning signal until all boats have finished racing.

23.3. A boat shall receive no outside assistance once she has left the dock for the day until her finish of the last race of the day, except in case of an emergency.

23.4. Coach and support vessels associated with a competitor shall check in with registration to receive their Identification stickers.

## **24. [NP] [DP] HAUL OUT RESTRICTIONS**

24.1. All boats shall be kept at their assigned locations corresponding with boats bow numbers at Sailing Club Mornar from 1800 on Sunday, 07 September until the end of the Championship. Boats shall comply with the docking and haul-out plan implemented by the OA.

## **25. [NP] [DP] DIVING EQUIPMENT AND PLASTIC POOLS**

25.1. Underwater breathing apparatus and plastic pools or their equivalent shall not be used around boats between the preparatory signal of the first race and the end of the Championship.

## **26. OFFICIALS**

Event Chair: Lenko Jakelic

Star Class President: Paul Cayard

Star Class Executive Director: Mike Hecky

Star Class Office: Jerelyn Biehl

Race Office: Luka Bonacic

Principal Race Officer: Marko Misura

Star Class Course Representative: Athanasios Papantoniou

Jury Chair: Hans Vengberg

Technical Committee Chair: Peter Moeckl

### **Addendums:**

- 1 – Vakaros RaceSense
- 2 - Harbor location and Racing area
- 3 – Venue map
- 4 - Bow number and advertising positioning
- 5 – Emergency Plan
- 6 - Courses

## **ADDENDUM 1 – Vakaros RaceSense**

### **[NP] Rules and Instructions for Using the Vakaros and RaceSense System**

1. The Vakaros RaceSense system will be used by the Race Committee (RC), and the relevant information will be available to all boats. As defined in RRS 41 (c).
2. Instructions for using the electronic Atlas 2 / Atlas Edge device will be posted on the Official Notice Board.
3. Competitors shall take all reasonable measures to keep the Atlas 2 / Atlas Edge safe and operational and promptly notify Vakaros staff on the water or ashore of any device issues.
4. RRS 26 is changed. The countdown to the start on the Atlas 2 / Atlas Edge from RaceSense will be the official time. Signal flags will only be used for information purposes.
5. The visual identification of boats infringing RRS 29 and RRS 30 by the RC is replaced with electronic identification through the Vakaros RaceSense system, modifying RRS 29.1, 30.1, 30.2, 30.3, and 30.4.
6. In the event a start needs to be postponed, for fairness or safety reasons, the RC will display code flag “AP”.
7. Any failure of the Atlas 2 / Atlas Edge, RaceSense system, or communication systems will not constitute grounds to request redress by a boat. This changes RRS 61.1(a).
8. If the RC vessel displays flag O with a sound signal before the warning signal of a race, rules 4. and 5. in this Addendum will not apply to that race. The Race will be started using RRS 26.
9. If the RC vessel displays flag R with a sound signal before the warning signal of a race, Competitors shall restart their Vakaros Atlas 2 / Atlas Edge unit by switching it off, waiting 10 seconds, and then switching it back on to reconnect to the RaceSense network. Flag R will remain displayed for a minimum of 2 minutes and will be removed with the next warning signal.
10. If firmware updates to Atlas 2 / Atlas Edge devices are required between scheduled race days, notice will be sent to all competitors via email or SMS/ and or the Regatta WhatsApp group and or the ONB.

## ADDENDUM 2 - Harbor location and Racing areas

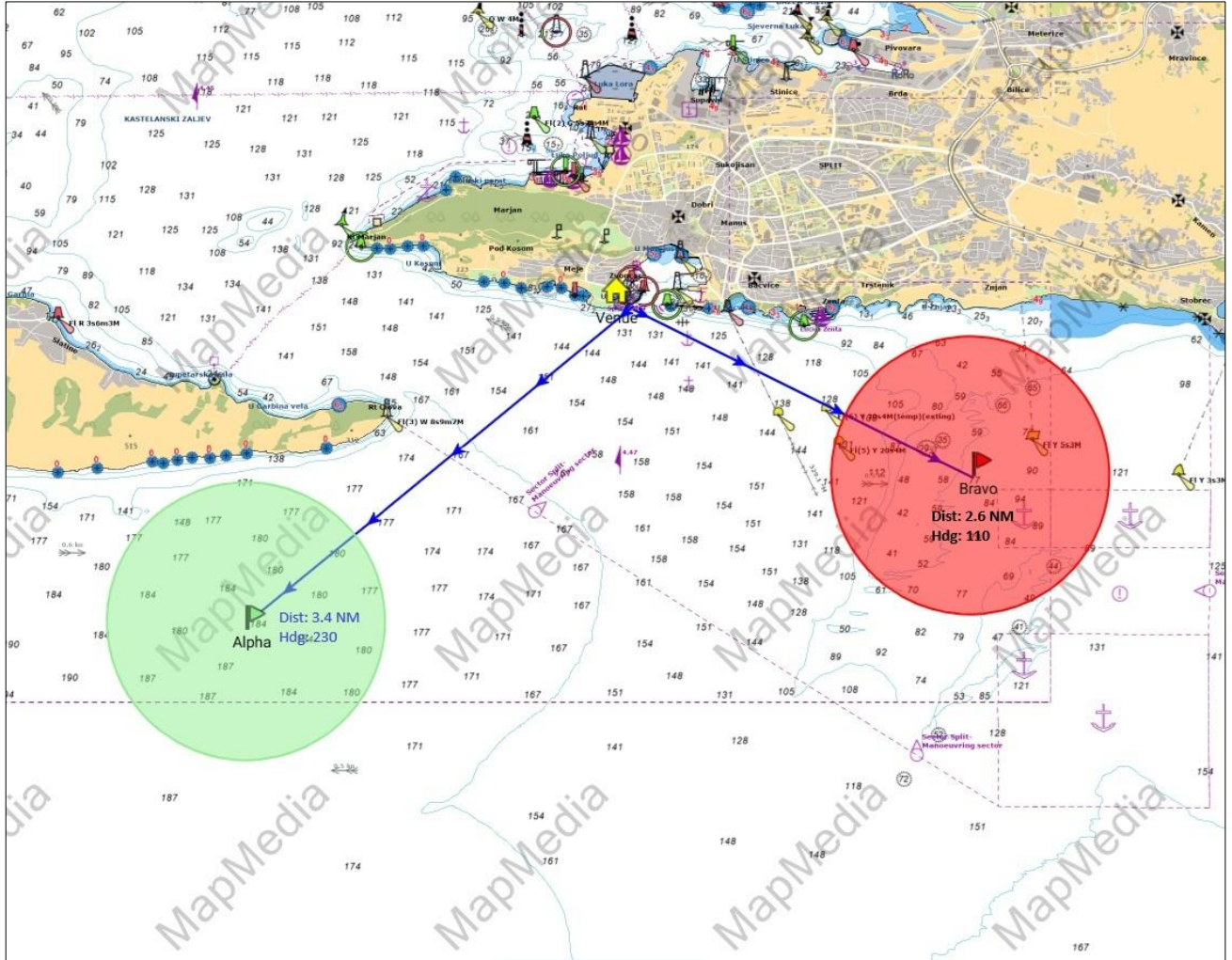

ADDENDUM 3 – Venue map

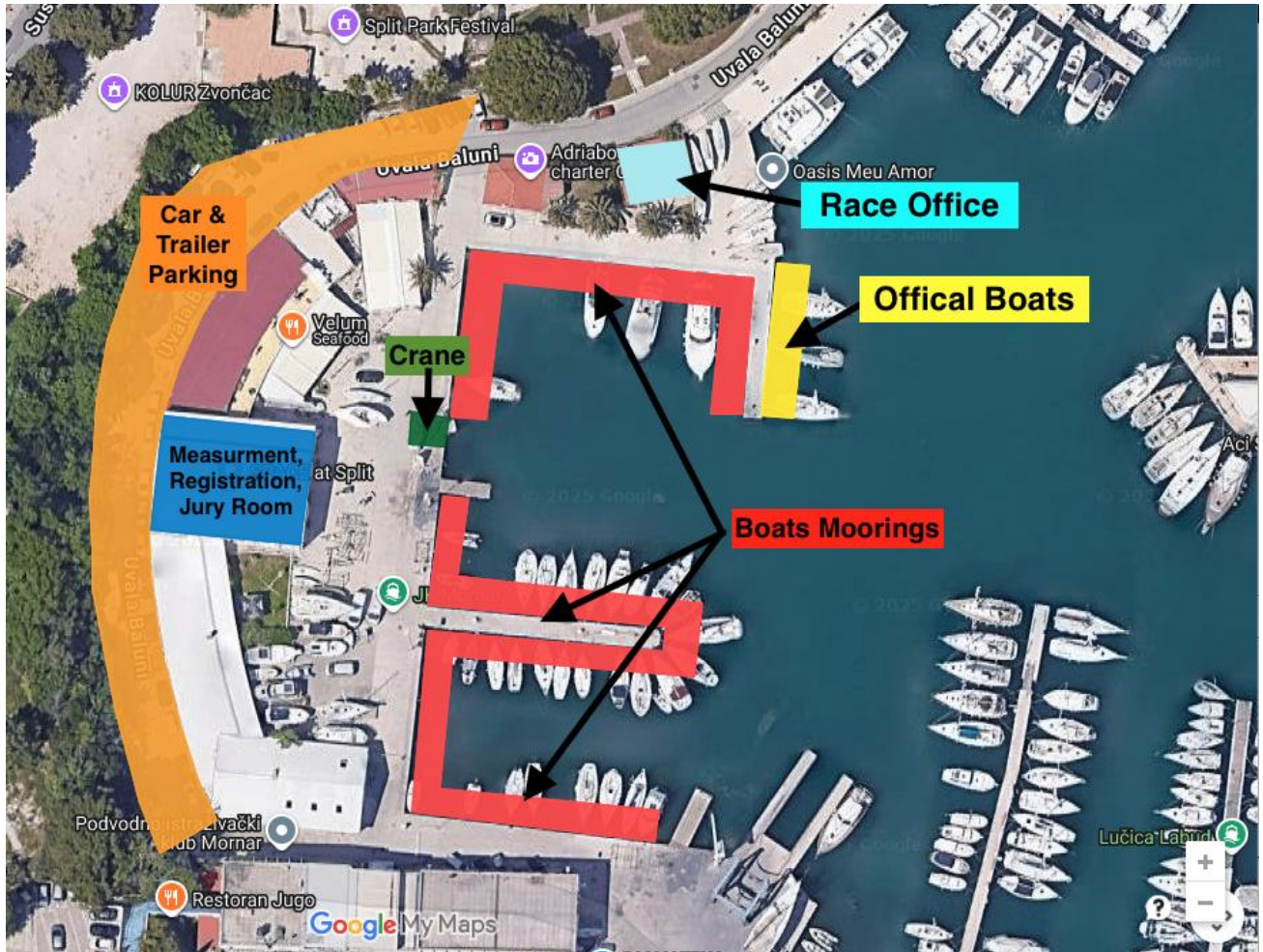

**ADENDUM 4 - Bow number and advertising stickers diagram**

# Starboard

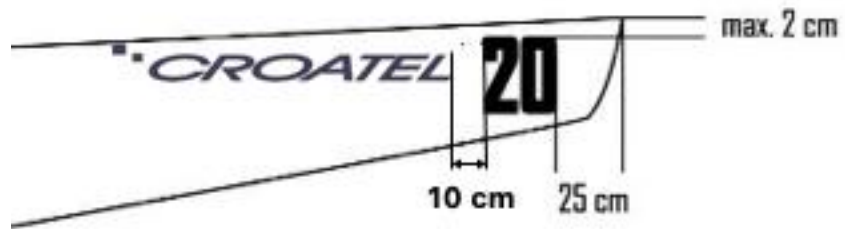

## **ADDENDUM 5 - Emergency Plan**

### **THERE WILL BE CMRS TEAM ON THE WATER AND ASHORE FOR EMERGENCY ASSISTANCE**

In the case of an emergency occurring on the water:

1. CALL THE RC BOAT VIA VHF CH. 69 or CALL by voice one of the official ribs
2. DESCRIBE THE STATUS OF THE ACCIDENT:
  - a. INJURY TO PERSON (AMBULANCE NEEDED Y/N)
  - b. DAMAGE TO THE BOATS (CRANE NEEDED)

IF AN **AMBULANCE IS NEEDED** ASHORE, PLEASE INFORM YOUR COACH RIB IS TAKING CARE OF THE INJURED PERSON, OR AN OFFICIAL VESSEL IS NEEDED FOR PICKUP!

3. THE PRO WILL INFORM THE CMRS TEAM immediately
4. THE CMRS TEAM WILL TAKE OVER THE SITUATION

### **AMBULANCE PICK UP LOCATION:**

THE APPROACH AREA IS RIGHT IN FRONT OF THE CLUB'S HANGAR AT CARNE LOCATION.

IF A **CRANE IS NEEDED FOR MAJOR HULL DAMAGES**, PLEASE PROCEED DIRECTLY TO THE CRANE LOCATION.

EMERGENCY ASHORE







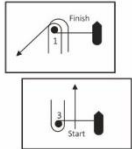
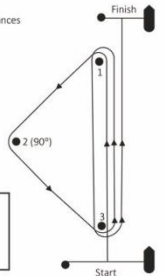
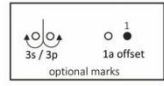
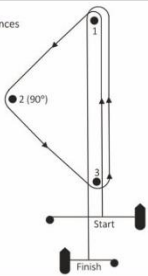

In case of an emergency occurring ashore, please:

- CALL EMERGENCY NUMBER 112
- REPORT TO RACE OFFICE

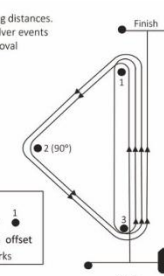
# ADDENDUM 6 - Courses

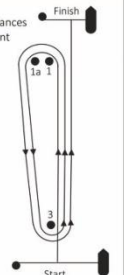
INTERNATIONAL STAR CLASS YACHT RACING ASSOCIATION

## COURSES

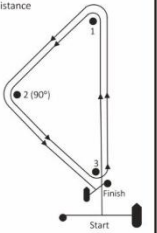
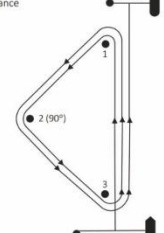
<p><b>Star Class Courses</b> (STCR 34.3 and 34.4)</p> <p>In case of small regattas, the starting line may be set up at mark 3 and the finishing line at mark 1</p> 	<p>Courses 0, 1, 2, 3, and 4 are diagrammed as described in STCR 34.3 and modified allowed by STCR 34.4.</p> <p>In Gold and Silver events, Course 0, 1, 3, or 4 shall be used. Course 2 may be used in Silver events if requested by the sponsoring fleet and approved by the Continental Committee. In Blue and Green events Course 0, 1, 2, 3, and 4 shall be used.</p> <p>No course may be shortened during Gold, Silver, Blue, or Green events.</p> <p>In Red events and Qualifications, the above courses are not mandatory and may be shortened.</p>	<p><b>Course "0"</b></p> <p>★ See STCR 34.3.9 for approximate leg distances ★ See STCR 34.4.5 for 1a offset guidance</p> <p><b>Start</b> 1 2 3 1 (or 1 + 1a offset) 3 (or gate 3s / 3p) <b>Finish</b> (upwind)</p>  
<p><b>Course "1"</b></p> <p>★ See STCR 34.3.9 for approximate leg distances ★ See STCR 34.4.5 for 1a offset guidance</p> <p><b>Start</b> 1 2 3 1 (or 1 + 1a offset) <b>Finish</b> (downwind)</p>  	<p><b>Course "2"</b></p> <p>★ See STCR 34.3.9 for approximate leg distances. ★ May not be used for Gold events. Silver events require Continental Committee approval (STCR 34.3.1)</p> <p><b>Start</b> 1 2 3 1 (or 1 + 1a offset) 3 (or gate 3s / 3p) 1 2 3 <b>Finish</b> (upwind)</p>  	
<p><b>Course "3"</b></p> <p>★ See STCR 34.3.9 for approximate leg distances ★ See STCR 34.4.5 for 1a offset requirement</p> <p><b>Start</b> 1 1a 3 (or gate 3s / 3p) 1 1a 3 (or gate 3s / 3p) <b>Finish</b> (upwind)</p>  	<p><b>Course "4"</b></p> <p>★ See STCR 34.3.9 for approximate leg distances ★ See STCR 34.4.5 for 1a offset requirement</p> <p><b>Start</b> 1 1a 3 (or gate 3s / 3p) 1 1a <b>Finish</b> (downwind)</p>  	
<p><b>Course "6"</b></p> <p>★ See STCR 34.3.9 for approximate leg distance</p> <p><b>Start</b> 1 2 3 1 2 3 <b>Finish</b> (off wind)</p> 	<p><b>Course "7"</b></p> <p>★ See STCR 34.3.9 for approximate leg distance</p> <p><b>Start</b> 1 2 3 1 2 3 <b>Finish</b> (upwind)</p> 	

206

2023 LOG